

TYPICAL PLAN (DOMESTIC)
(‘TYPE KC’ KERB SHOWN)

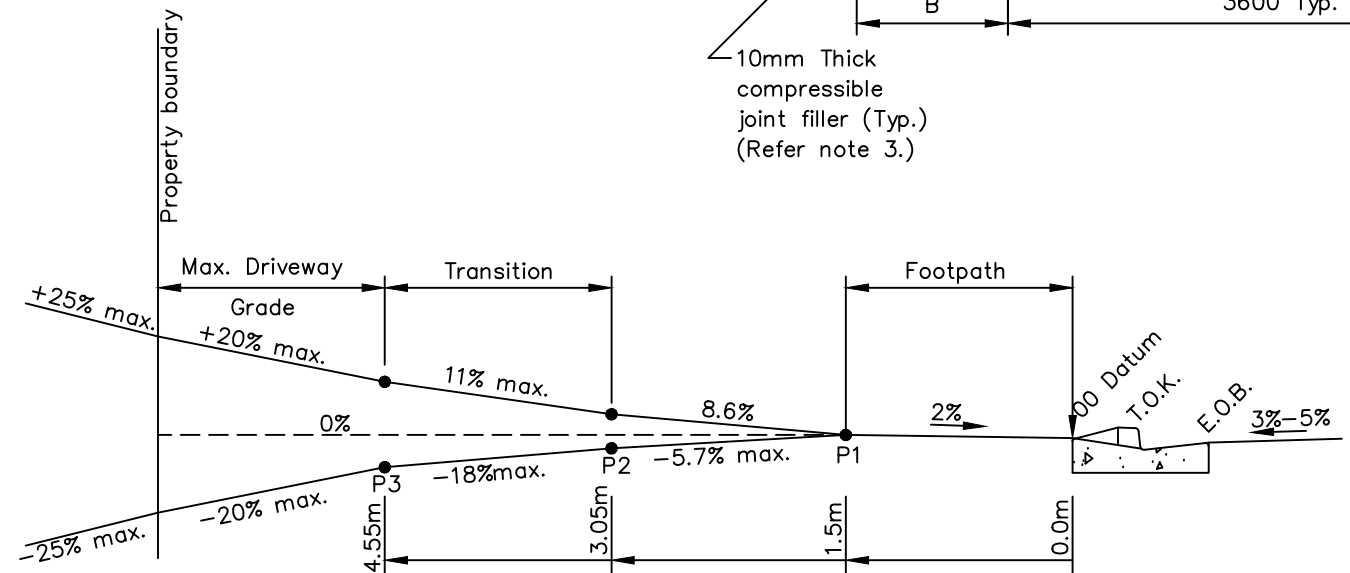

TYPICAL DRIVEWAY PROFILE
SUITS ‘B85’ / ‘B99’ VEHICLES
(‘TYPE KC’ KERB / FOOTPATH AT KERB SHOWN)

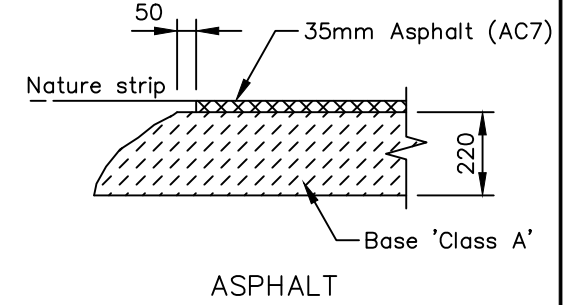
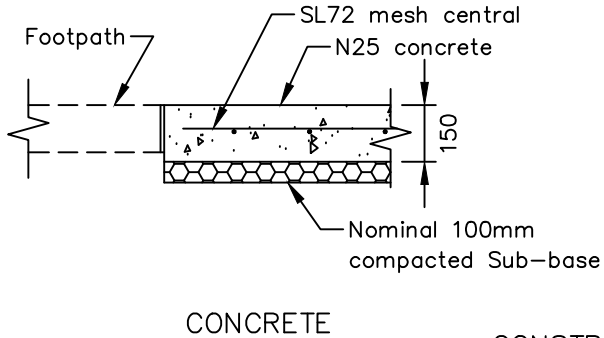
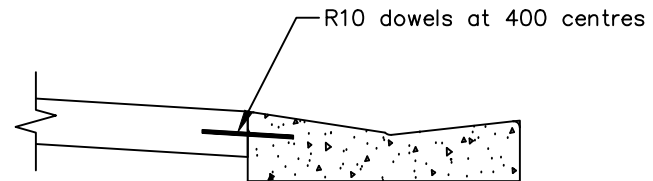

DIMENSION TABLE – PLAN VIEW		
Dim.	Description	Notes
A	Boundary Offset	New Subdivisions – 1000mm min. Established areas – Match existing
B	Transition (Wing)	Types ‘KC’ and ‘KCM’: B = 1000mm
C	Min. kerb Length	Delete transitions and construct continuous crossing if ‘C’ IS < 500mm

CONSTRUCTION NOTES

1. Concrete surfaces – Edge tooled, broom finish.
2. The Principal may increase depth of base course(s) for subgrade strength (C.B.R. < 4.0%)
3. Extend 10mm compressible joint filler through concrete footpaths only (Refer sheet TSD-R11, Footpaths).

DESIGN NOTES

4. Design driveway profiles (tabulated) are in accordance with the requirements of ‘AS/NZS 2890.1 : 2004’ using ‘Standard Design Vehicles’:
 - B85 Vehicle – Domestic driveways (including 1 – 2 units)
 - B99 Vehicle – Light commercial, large unit development.
5. An approved engineering design is required for varying site conditions and for driveways used by ‘Non Standard’ vehicles, detailing the structural, plan geometry and vertical profile requirements.
6. Maximum driveway width to be determined by a Council Officer
7. Fibre reinforcement is permissible but must be approved by the General Manager’s delegated officer and the local council

SCALES: AS SHOWN
(All scales are correct at A3)

XRef File: TSD-R09-v2.dwg

REFERENCES

©2012
This drawing and the information it contains is, and remains the property of the Local Government Association of Tasmania, and may only be used for the purpose of which it was intended. Reproduction of this drawing or its content in any format other than printed hard copies is strictly prohibited.
It is the users responsibility to ensure this drawing is the current version. The current version can be downloaded from: www.lgat.tas.gov.au

TAS Division
IPWEA
INSTITUTE OF PUBLIC WORKS
ENGINEERING AUSTRALIA

LGAT Local Government Association Tasmania

STANDARD DRAWING
URBAN ROADS
DRIVEWAYS

GPO Box 1521, Hobart Tasmania 7001 | 326 Macquarie Street, Hobart Tasmania 7000
T: 03 6233 5966 F: 03 6233 5986 Email: admin@lgat.tas.gov.au

ISSUE DATE: 28-04-2020 DWG No. TSD-R09-v2